



13th International Conference on Greenhouse Gas Control Technologies, GHGT-13, 14-18  
November 2016, Lausanne, Switzerland

## Chemical-Looping Combustion of Solid Fuels – status and recent progress

Anders Lyngfelt\* and Carl Linderholm

*Department of Energy and Environment, Chalmers University of Technology, S-412 96 Göteborg, Sweden*

---

### Abstract

Chemical-Looping Combustion of solid fuels has been studied for ten years and significant progress has been made. The paper discusses operational experiences and various aspects of up-scaling, including similarities to fluidized-bed combustion, key challenges, cost structure and strategies for reducing costs for demonstration. Based on more than 9000 h of CLC operation in 34 pilots, of which >3000 h with solid fuels, it is concluded that there are oxygen carrier materials suitable for solid fuels, and that the technology should be ready for scale-up.

© 2017 The Authors. Published by Elsevier Ltd. This is an open access article under the CC BY-NC-ND license (<http://creativecommons.org/licenses/by-nc-nd/4.0/>).

Peer-review under responsibility of the organizing committee of GHGT-13.

*Keywords:* Chemical-Looping Combustion; CO<sub>2</sub> capture;

---

---

\* Corresponding author. Tel.: +46-31 772 1427; fax: +46-31-772 3592.  
*E-mail address:* Anders.Lyngfelt@chalmers.se

## 1. Introduction

### 1.1. Why Chemical-Looping Combustion ?

Conventional CO<sub>2</sub> capture processes have large costs and energy penalties associated with gas separation. Chemical-looping combustion (CLC) is a new combustion principle that uses metal oxides for oxygen transfer from air to fuel. Thus, fuel can be oxidized without mixing fuel and combustion air and the combustion products, i.e. CO<sub>2</sub> and steam, are recovered in a separate flow without any active gas separation. After condensation of steam essentially pure CO<sub>2</sub> is obtained. Thus, CO<sub>2</sub> capture is inherent in the process and costs and penalties for gas separation may be avoided. Other advantages involve the improved possibilities to reduce emissions of SO<sub>2</sub> and NO<sub>x</sub> because the pollutants will be concentrated in the smaller flow from the fuel reactor. This may also apply to ash components known to create difficulties, e.g. alkali in biomass.

### 1.2. What is Chemical-Looping Combustion ?

The reactor system can be built as a system of two interconnected fluidized beds, the air reactor and the fuel reactor, with an oxygen carrier in the form of a metal oxide circulating between the two beds. The general principle is shown in Figure 1 and an example showing how the process could be designed using the circulating fluidized bed principle for the transfer of particles between the two reactors is shown in Figure 2.

CLC research and development initially had a focus on gaseous fuels, but the last ten years important work has been dedicated to CLC of solid fuels. Technology overviews are given in a number of reviews, e.g. [1-5].

In the case of gaseous fuels, these are introduced through the bottom plate as fluidizing gas, thus achieving a good distribution over the cross-section. As the gas moves upwards through the bed it is gradually converted and if conditions are suitable the gases are fully oxidized to CO<sub>2</sub> and H<sub>2</sub>O as they leave the reactor, as shown in pilot testing with gaseous fuels like natural gas [6]. Chemical-looping combustion of solid fuels could use the general circulating fluidized bed (CFB) concept outlined in Figure 2, but the fuel reactor system needs to be adapted for use of solid fuels.

When heated, solid fuels release gaseous combustible compounds (volatiles) that may react with the oxygen carrier to form CO<sub>2</sub> and H<sub>2</sub>O. After the release of volatiles there is a remaining char that also needs to be burnt. The reaction between the oxygen-carrier and the char remaining after release of volatiles is not direct, but involves an intermediate gasification step, i.e.  $C + H_2O \Rightarrow CO + H_2$ , Figure 3.

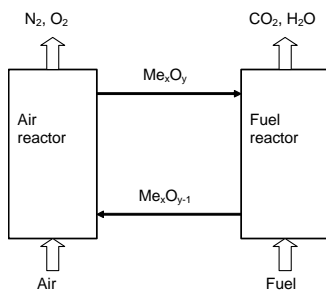

Figure 1. CLC principle. Me<sub>x</sub>O<sub>y</sub> is the metal oxide circulated.

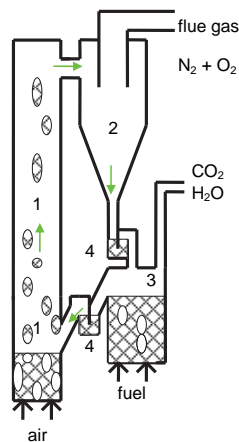

Figure 2. CFB reactor system for gas, 1) air reactor, 2) cyclone, 3) fuel reactor 4) loop seals

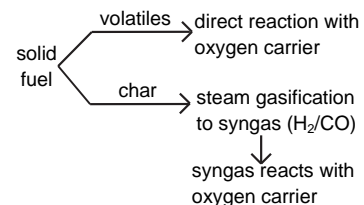

Figure 3. Solid fuel reactions in CLC

### 1.3. Chemical-Looping with Oxygen Uncoupling (CLOU)

Chemical-Looping with Oxygen Uncoupling (CLOU) is closely related to chemical-looping combustion and but differs from CLC through the spontaneous release of oxygen in the fuel reactor. Thus, instead of the fuel gas reacting directly with the oxide, the oxidation of the fuel involves two distinct steps, first the release of gaseous oxygen and then the combustion of the fuel by the oxygen released, Figure 4.

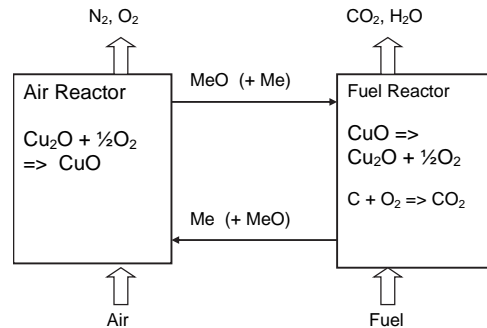

Fig. 4. Chemical-Looping with Oxygen Uncoupling (CLOU) using CuO/Cu<sub>2</sub>O. The fuel is carbon.

The CLOU process requires an oxygen carrier with the ability to react with the oxygen in the combustion air in the air reactor, but which decomposes to a reduced metal oxide and gas-phase oxygen in the fuel reactor. Three monometallic oxide systems with feasible thermodynamic properties have been identified, Mn<sub>2</sub>O<sub>3</sub>/Mn<sub>3</sub>O<sub>4</sub>, CuO/Cu<sub>2</sub>O and Co<sub>3</sub>O<sub>4</sub>/CoO, [6]. Co<sub>3</sub>O<sub>4</sub>/CoO has the disadvantage of an overall endothermic reaction in the fuel reactor, as well as high costs and risks with respect to health and safety. The equilibrium oxygen concentration is 5% for Mn<sub>2</sub>O<sub>3</sub>/Mn<sub>3</sub>O<sub>4</sub> at a temperature around 800°C. For CuO/Cu<sub>2</sub>O it is 5% at a temperature around 950°C. In a combustion process most of the oxygen in the combustion air needs to be consumed in order to avoid large flows and thermal losses with exiting flue gas. This means that the O<sub>2</sub> concentration in the air reactor outlet would need to be low, preferably 5% or less. Thus, for the Mn-system we would need to be below around 800°C in the air reactor. The reactions at these temperatures, however, appear to be too slow and no successful work with Mn<sub>2</sub>O<sub>3</sub>/Mn<sub>3</sub>O<sub>4</sub> as CLOU material is known presently. However, CLOU using CuO has been shown to work, first in laboratory batch fluidized-bed tests with CuO and solid fuel, [7, 8] and later in continuous operation with solid fuel [9].

Although the CLOU mechanism is clearly useful for any fuel, the advantages are very obvious for solid fuels. In other proposed schemes for using chemical-looping combustion of solid fuels there is a need for an intermediate gasification step, Fig. 3. The gasification of char with H<sub>2</sub>O and CO<sub>2</sub> is slow, which may cause losses of unconverted char. This gasification step can be avoided in CLOU.

An additional option for CLOU is combined manganese oxides, having lower equilibrium oxygen partial pressures than the pure manganese system, and thus possible to oxidize at higher temperatures, [10]. Most of these materials can only release limited amounts of the oxygen in this way, but this could still be quite beneficial for the conversion of both solid and gaseous fuels. Interestingly, there is one material that has been shown to be able to rapidly release large quantities of oxygen, a 4:1 mixture of manganese and iron oxide, [11]. Long-term stability of this material has not been shown yet, however. Good operational results have been obtained with calcium manganite, [12], but unfortunately this material is sensitive to sulphur so it cannot be used with all fuels.

### 1.4. Scope and focus of paper

The scope of the paper includes:

- a summary of the experiences from pilot operation with respect to important performance parameters
- a discussion of what these experiences can learn for the full-scale application, i.e. what performance can be expected, and what measures are needed to meet incomplete performance.
- a discussion of scale-up issues, possible full-scale design, and possible strategies for the upscaling
- a discussion of costs based on comparison to conventional circulating fluidized-bed power boilers.

It should be said that a large variety of process concepts including chemical-looping technology have been proposed that utilize gaseous, liquid and solid fuels, involving different products such as steam, power and hydrogen. Most systems use fluidized-beds, but there are also systems involving moving beds and fixed beds as well as rotating reactors. This paper is concerned with the use of solid fuels, such as coal and biomass, in interconnected fluidized-beds. This is based on the belief that this represents the most important future market of CLC, given the expected large cost benefit of this process in relation to existing CO<sub>2</sub> capture technologies for solid fuels, in combination with the large importance of applying CO<sub>2</sub> capture to solid fuels. This is firstly because coal is by far the largest emitter of CO<sub>2</sub> from large point sources suitable for CO<sub>2</sub> capture, and secondly because of the unequivocal need for large negative emissions, [13], which would also involve solid fuel, i.e. biomass.

### 1.5. Nomenclature

The process discussed here is Chemical-Looping Combustion of Solid Fuels, or CLC-SF. However, since the paper only discusses the use of solid fuels, CLC is normally used for convenience. CLC-SF is not to be confused with iG-CLC (insitu Gasification CLC), which is normally used to indicate a CLC-SF process where no CLOU takes place. Here, CLOU is seen as a possible mechanism of CLC-SF that may improve the conversion of gas and char. Many natural materials, like manganese ores and ilmenite, have been shown to have the ability to release some oxygen, which means that they are CLOU materials to some extent. Consequently, the process will become a mixture of CLOU and the normal CLC reaction for many materials. In practice it would likely be difficult to assess the extent of each mechanism.

There is also the possibility to gasify the coal before supplying it to the CLC process, but then it is obviously a gaseous fuel, and not a solid fuel, that is used being used in the CLC process.

### 1.6. Process Performance

Both release of volatiles and char gasification have important implications for the design of the fuel reactor. Ideally, the fuel will be completely converted to CO<sub>2</sub> and H<sub>2</sub>O in the fuel reactor. In the case of solid fuels, a fully oxidized gas is normally not attained, which can be remedied by adding oxygen in a post-oxidation chamber downstream of the fuel reactor, so-called “oxy-polishing”. Figure 5 illustrates the three deviations from the ideal case; i) loss of combustible gases like H<sub>2</sub>, CO and CH<sub>4</sub> in the gas leaving the fuel reactor; ii) loss of char to the air reactor; and iii) loss of char with the gas leaving the fuel reactor. The corresponding performance indicators are:

i. Oxygen demand,  $\Omega_{OD}$ , is the oxygen required to oxidize unburnt gas leaving the fuel reactor to CO<sub>2</sub> and H<sub>2</sub>O over the total oxygen needed to oxidize the gases released from the fuel in the fuel reactor.  $1-\Omega_{OD}$  is the gas conversion. The oxygen demand indicates the oxygen needed for oxy-polishing.

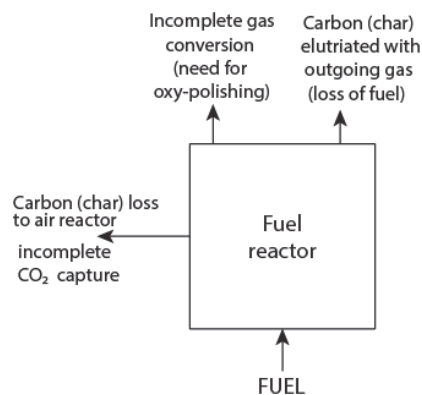

Figure 5. Inadequate performance of the fuel reactor.

ii.  $\text{CO}_2$  capture,  $\eta_{\text{CO}_2}$ , is the fraction of gaseous carbon leaving the fuel reactor related to the total carbon converted to gas in fuel and air reactors. Thus,  $1-\eta_{\text{CO}_2}$  represents the ratio of the carbon lost as  $\text{CO}_2$  from the air reactor to the total carbon in gaseous compounds leaving air and fuel reactors.

iii. Fuel conversion,  $\eta_F$ , is used to indicate the char conversion and is defined as the ratio of carbon converted to gaseous compounds in the fuel and air reactors to total carbon added. Consequently, carbon loss, *i.e.*  $1-\eta_F$ , is the fraction of total carbon added that is elutriated from the fuel reactor in the form of char.

### 1.7. Oxygen-carrier lifetime

In addition to the three performance indicators above, relating to the process performance in terms of fuel conversion, there are other aspects of chemical-looping process to consider. One is the oxygen-carrier lifetime, which cannot be too short if the cost of supplying oxygen-carrier is to be reasonable. For the solid fuel application, ores are normally considered, for which a lifetime of a few hundred hours would be sufficient to avoid a high cost of material supply, [14]. Manufactured materials are likely an order of magnitude higher in cost, which would mean they would need a similar increase in lifetime to give costs comparable to ores. Waste materials may be an option to further reduce the cost of material.

Comparisons between lifetime estimations made from actual operation, and material tests of attrition and crushing strengths indicate a limited correlation, [15]. Likely, this is due to different stresses at high temperature with cyclic reduction and oxidation of the material. Therefore, actual operation of materials in CLC seems to be the only safe way of evaluating materials.

## 2. Operational experiences

### 2.1. Pilot operation

More than 70 different materials have been used in operation of small CLC pilots, as reported from more than 150 publications. Table 1 shows reported operational time of different categories of materials. Totally, more than 9000 h has been reported, of which >3000 h with solid fuels.

Among the manufactured materials the monometallic oxides dominate, but in the last years a number of publications also report the use of combined oxides, normally combined manganese oxides or perovskites. Nickel oxides is by far the most used material followed by iron, whereas the operation with manganese based materials is quite small. At least for the solid fuel application the use of nickel oxides can be excluded as it is expensive, toxic and not compatible with sulphur.

Table 1. Operation in CLC with various types of oxygen carriers

	Reported operational time, h	Of which solid fuels
<u>Manufactured materials:</u>		
Nickel	3167	267
Copper	1036	158
Manganese	91	0
Iron	1652	1070
Cobalt	178	0
Combined oxides	718	106
<u>Ores or waste materials:</u>		
Iron	847	624
Ilmenite	1163	717
Manganese	243	158
Calcium sulfate	75	75
<u>Total Manufactured</u>	6842	1601
<u>Total ores/waste</u>	2328	1574
<u>Total</u>	9170	3175

In the later years the interest for low-cost materials has grown together with the use of solid fuels. Here ilmenite is the most used material, followed by iron ores. Some operation of manganese ores have also been reported. Operation with calcium sulphate, i.e. spent bed material from circulating fluidized beds, has also been made reported, but the results are not so detailed.

Table 2 Small scale pilots used in CLC operation

Location	Unit	Oxides tested	Fuels\references	Year
Chalmers	10 kW-GL	NiO, Fe <sub>2</sub> O <sub>3</sub> , CaMnO <sub>3</sub> , ilmenite	nat. gas, oil [16] [17]	2004
KIER	50 kW	NiO, CoO	nat. gas [18]	2004
CSIC	10 kW	CuO, NiO	nat. gas [19]	2006
Chalmers	0.3 kW	NiO, Mn <sub>3</sub> O <sub>4</sub> , Fe <sub>2</sub> O <sub>3</sub> , CuO, ilmenite, CaMnO <sub>3</sub> , Mn/Fe, Mn/Mg, Mn/Si, Mn/Fe/Si, Mn ore	nat. gas, syngas [20]	2006
Chalmers	10 kW-SF	ilmenite, manganese ore	coal, petcoke [21] [22]	2008
CSIC	0.5 kW-GL	CuO, NiO, Fe <sub>2</sub> O <sub>3</sub> , CaMnO <sub>3</sub> ,	nat. gas, acid gas, sour gas, ethanol [23]	2009
KAIST	1 kW	NiO + Fe <sub>2</sub> O <sub>3</sub>	CH <sub>4</sub> [24]	2009
Vienna UT	140 kW	ilmenite, NiO, CuO	nat. gas, CO, H <sub>2</sub> [25]	2009
Alstom	15 kW	NiO	nat. gas [26]	2009
Nanjing	10 kW-SF	NiO, Fe <sub>2</sub> O <sub>3</sub>	coal, biomass. [27]	2009
KIER	50 kW	NiO, CoO	nat.gas, syngas [28]	2010
Nanjing	1 kW – SF	Fe <sub>2</sub> O <sub>3</sub> (ore)	coal, biomass, sewage sludge [29] [30]	2010
IFP-Lyon	10 kW-GSF	NiO, CuO, Mn ore	CH <sub>4</sub> , coal, syngas [31] [32]	2010
Stuttgart	10 kW	ilmenite	syngas [33]	2010
Xi'an Jiaotong	10 kW- Pr	CuO/Fe <sub>2</sub> O <sub>3</sub>	coke oven gas [34]	2010
CSIC	1.5 kW-SF	ilmenite, CuO, Fe <sub>2</sub> O <sub>3</sub>	coal [35]	2011
Chalmers	0.3 kW LF	NiO, Mn <sub>3</sub> O <sub>4</sub> , CuO	kerosene [36]	2011
Chalmers	100 kW – SF	ilmenite, Fe ore, Mn ore	coal, petcoke, wood char [37] [38]	2012
Hamburg	25 kW –SF	ilmenite	coal, CH <sub>4</sub> [39]	2012
Ohio	25 kW –SF	Fe <sub>2</sub> O <sub>3</sub>	coal [40] [41]	2012
Nanjing	50 kW-Pr	iron ore	coal [42]	2012
Tsinghua	0.2 kW	ilmenite	CO [43]	2013
Darmstadt	1 MW –SF	ilmenite	coal [44] [45]	2015
Alstom	3 MW –SF	CaSO <sub>4</sub> /CaS	coal [46]	2014
CSIC	50 kW-SF	ilmenite, iron ore, CuO/Fe <sub>2</sub> O <sub>3</sub> /MgAl <sub>2</sub> O <sub>4</sub>	coal, lignite, anthracite [47]	2014
Huazhong	5 kW-GSF	iron ore	CH <sub>4</sub> coal [48]	2015
Guangzhou	10 kW-G	Fe <sub>2</sub> O <sub>3</sub>	saw dust [49]	2015
Nanjing	25 kW-G	NiO, iron ore	rice husk [50]	2015
KIER	200 kW	NiO	nat. gas [51]	2016
Huazhong	5 kW-SF	iron ore	coal [52]	2016
Sintef	150 kW	CuO	CH <sub>4</sub> [53]	2016
VTT	20 kW-SF	ilmenite	biomass [54]	2016
NETL	50 kW	CuO/Fe <sub>2</sub> O <sub>3</sub>	CH <sub>4</sub> [55]	2016
Chalmers	1.4/10 MW	ilmenite, Mn ore	biomass [56]	2016

SF-solid fuel, GSF-gaseous & solid fuel, Pr-pressurized, LF-liquid fuel, GL=gaseous/liquid fuel, G-Gasification

The reported operation has been accomplished in 34 smaller pilots sized 0.2 kW to 3 MW, Table 2. The systems normally have a high-velocity air reactor that works as a riser moving the material to the fuel reactor via a cyclone. The air reactor may also have a wider bottom part with lower velocity. There are also systems using a separate riser or using the fuel reactor as riser. The solids may be returned from the fuel reactor to the air reactor via an overflow

exit, via a direct fluidized connection below the reactor, via a separate riser or using the fuel reactor as a riser to return the material. Control of circulation can be done by fluidizing velocity in risers, by mechanical valves or by split loop seals. In the case of the Ohio pilot, the fuel reactor is a moving bed, i.e. it is not fluidized.

The list includes two units used for chemical-looping gasification. Moreover, the list includes a 10 MW circulating fluidized-bed boiler (CFB). [56] This boiler is used for district heating, but is well equipped for research and also includes a gasifier. Although not built for the purpose of chemical-looping, the gasifier can be used as a fuel reactor, albeit not at full fuel power. Ilmenite and a manganese ore were used mainly in Oxygen-Carrier Aided Combustion (OCAC), where oxygen-carrier materials is used to improve combustion performance. In total the ilmenite was in continuous operation for 900 h and the Mn ore for 500 h. During this operation fuel was added to the gasifier/fuel-reactor for periods of typically 8 h, corresponding to a fuel power of 1.4 MW. Total operation in CLC mode is 62 / 32 h for ilmenite / Mn ore. The operation shows that oxygen carriers can be used in an industrial environment. Furthermore, 4000 h of successful OCAC operation of a 75 MW<sub>th</sub> CFB with ilmenite has been reported giving further evidence that oxygen carrier materials can be used under industrial conditions, [57].

Small scale operation shows that all three performance indicators vary considerably depending on fuel, oxygen carrier, pilot design, solids inventory in fuel reactor, as well as operating conditions such as temperature, fuel feeding rate and solids circulation. Many of the observations from the operation are in line with what can be expected. Thus, more reactive oxygen carriers show better performance, higher temperature is very important to achieve good char conversion, high solids inventory gives better gas conversion, etc.

One result which is quite interesting is the strong correlation between volatiles content and oxygen demand. Fig. 6 shows results from the Chalmers' 100-kW unit, clearly indicating that low-volatile fuels or char are associated with low oxygen demands, in contrast to high-volatile fuels having very high oxygen demand. The likely explanation is that volatiles are released into the bubble phase which, to a large extent, bypasses the dense particle phase. On the other hand the very low oxygen demand of the char indicates that the char particles are well mixed into the dense phase, allowing the syngas released from steam gasification to be released into the dense phase in close contact with oxygen carrier material. A film of a cold-flow model of the 100 kW unit shows the fluidization behavior of the unit, [58].

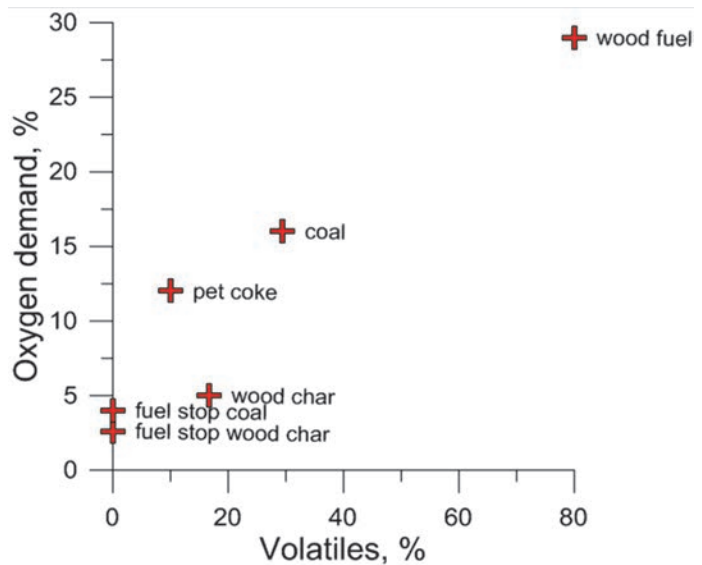

Figure 6. Oxygen demand vs volatiles in 100 kW unit

Figures 7-9 shows three larger CLC pilots for solid fuels, and Table 3 gives a comparison of some performance results achieved in these units. The 3 MW Alstom CLC unit was not included because of less detail in the data published. The performance of the 1 MW unit was studied using ilmenite and two quite different sizes of coal. The first case was pulverized coal (PC) and the second was larger coal (LC) particles of up to 8 mm size, and in both cases a large loss of carbon from the fuel reactor was observed, either to the air reactor or elutriated:

- For pulverized coal there is a very large loss of elutriated carbon from fuel reactor, 50%, in addition to the loss to the air reactor, as indicated by a carbon capture of 80%.
- For the larger coal the carbon loss falls to 5%. Instead, there is a very large loss of char to the air reactor, as indicated by a carbon capture of only 50%. Thus, residence time is too short to convert the larger coal particles in the fuel reactor.
- Operation of pulverized coal and ilmenite was also investigated in the 100 kW unit. The loss of carbon by elutriation from the 100 kW unit was also high, but lower than in the 1 MW unit, 30-40%. Further, the loss of carbon to the air reactor was low, as indicated by the high carbon capture. Moreover, the oxygen demand is somewhat lower in the 100 kW unit. Results for the 100 kW with a mixture of ilmenite and a manganese ore showed similar results for carbon capture and loss of carbon by elutriation. However, lower oxygen demand was attained.

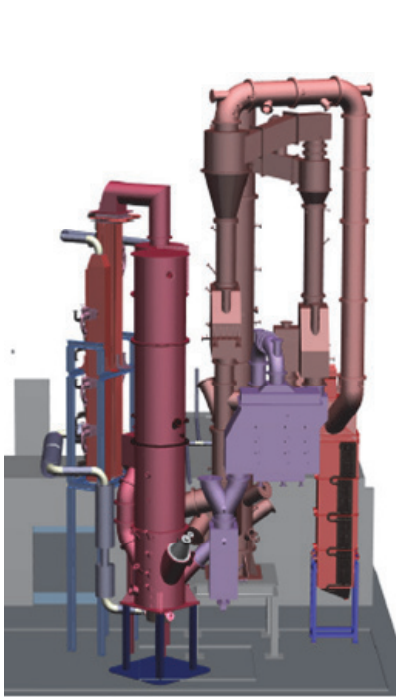

Fig 7. Darmstadt 1 MW unit.

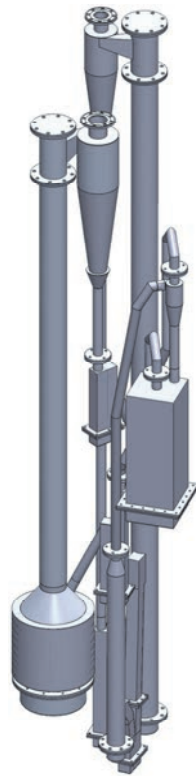

Fig. 8. Chalmers 100 kW unit.

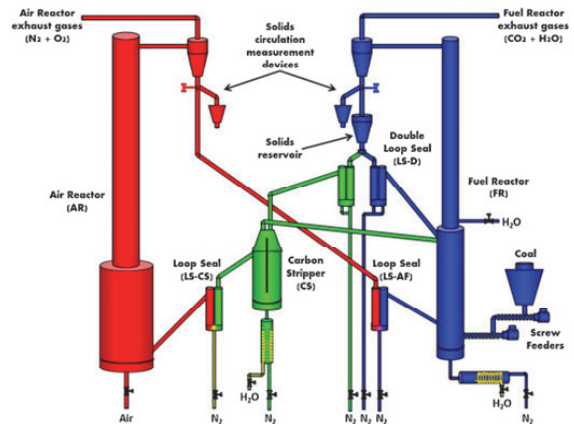

Fig 9. CSIC 50 kW unit.

Operation using an intermediately sized coal (IC) in the 100 kW unit showed a significantly lowered loss of carbon by elutriation, but without any measurable increase in the loss to the air reactor. Further, the oxygen demand was improved, which can be attributed to the use of a more reactive oxygen carrier, a manganese ore.

Finally, results from the 50 kW pilot, operated at 13.5 kW with another coal of intermediate size, also showed low loss from elutriation. Further, the results from the 50 kW unit showed lower oxygen demand but higher loss of carbon to air reactor in comparison to the 100 kW unit.



The differences between the results at Chalmers and in Darmstadt are possible to explain as follows:

- The circulation in the 1 MW unit is not sufficient to reach adequate fuel reactor temperature, resulting in slow char conversion, which increases loss of char.
- The solids inventory in the fuel reactor of the Darmstadt unit is low, resulting in short residence time for char to convert, i.e. larger loss to air reactor. It also means less contact between reacting gas and oxygen carrier, resulting in higher oxygen demand.
- The autothermal testing with “large coal” was done without carbon stripper in order to reduce cooling. Thus, it was possible to attain auto-thermal operation. This also contributes to high loss to AR, but the main reason is likely the fuel size. The PC firing on the other hand was made with a carbon stripper, nevertheless there was a significant loss to the air reactor.
- The fuel inlet in the 1 MW is high, 0.69 m above the nozzle plate, meaning that fuel is fed in the uppermost part of the dense bottom bed. This gives poorer contact between volatiles released and oxygen carrier, i.e. higher oxygen demand.

Table 3. Comparison of larger CLC pilots.

	1 MW Darmstadt, ilmenite		<----- 100 kW at Chalmers ----->			50 kW, CSIC
	PC [44] <sup>1</sup>	LC [45]	PC, ilm [59]	PC, ilm + Mn ore 1 [60]	IC, Mn ore 2 [61]	IC, ilm, test 6 [62]
Carbon capture, $\eta_{CO_2}$ [%]	80	44-52	98-99	99	99	90
Carbon loss by elutriation, $1-\eta_F$ [%]	50	5	35	(26-46)	8-12	7
Oxygen demand, $\Omega_{OD}$ [%]	20 <sup>1</sup> (26-38)	22-28	17-25	8.5-18	11-17	10
Pressure drop fuel reactor, kPa		7.5	<-----	14-25	----->	9
Solids inventory, kg/MW	156	105	<-----	300-500 <sup>2</sup>	----->	480
T FR, °C	900	920-950	965-980	960-974	970-980	990

<sup>1</sup> Propane and air added to fuel reactor to keep up temperature. <sup>2</sup> fuel reactor, PC = pulverized coal: a majority below 90  $\mu\text{m}$ , LC = larger coal, <8 mm, IC = intermediate sized coal: a majority in the size range 90-300  $\mu\text{m}$ .

The oxygen demand in the 1 MW is higher than in Chalmers 100 kW, which is expected in view of lower solids inventory, lower temperature and the high fuel entry mentioned above. The much higher loss of char to the air reactor and by elutriation also means that less syngas is formed, which should also raise the oxygen demand. This is because the oxygen carrier is more reactive towards syngas than the hydrogen-containing volatiles, in addition to the volatiles having poorer contact with the bed material. Adding all these effects it is reasonable to expect a larger difference in oxygen demand than what was observed. However, the fluidizing conditions in the Darmstadt unit are significantly better with a riser twice as high with a significant pressure drop, where good contact between gas and solids is expected. This is in contrast with the low ratio of diameter / bed height in the 100 kW unit giving slugging conditions. In conclusion it would be expected that raised solids inventory, feeding of fuel in the low part of the bed in combination with higher temperature would give a significant improvement and most likely lower oxygen demand as compared to the 100 kW unit.

The following can be concluded from the comparison:

- The fuel size is critical, pulverized coal gives large losses of unconverted char, whereas large fuel particles results in poor CO<sub>2</sub> capture. However, with an intermediate size it possible to achieve high char conversion in the fuel reactor as indicated by the results in the 50 and 100 kW pilots. Thus a size range of around 100 to 300  $\mu\text{m}$  is probably optimal.
- To reach good CO<sub>2</sub> capture, sufficient temperature and solids inventory are needed in the fuel reactor.
- The fuel should be fed as low as possible in the fuel reactor bed to achieve good contact between bed material and volatiles released.

- The results from the two smaller units indicate that good or reasonable performance could be reached simultaneously for all the three key performance criteria. This was not the case for the 1 MW unit. However, the reasons for inadequate performance are well understood as well as the measures needed to improve performance.

### 3. Up-scaling

#### 3.1. Similarities to FBC and key differences

The CLC process has important similarities to normal combustion of solid fuels in circulating fluidized bed (CFB) boilers. Thus, CFB combustion is an integral part of the state of art for CLC. A comparison of technology and costs between a 1000 MWth CFB boiler and a 1000 MWth CLC boiler has been made, [63]. The two boilers are outlined in Figure 10. Important differences and similarities are:

- The horizontal cross-section area is similar, because similar fluidization velocities are used.
- In the case of CLC the combustion chamber is divided in three parts, with one adiabatic fuel reactor in the middle surrounded by two air reactors.
- The same number of cyclones are used but the flows from all the cyclones are led to the fuel reactor. The flows from the four air reactor cyclones are fed into the fuel reactor above the bottom bed, whereas the internally circulating flows of the two fuel reactor cyclones enter in the bottom bed. The latter is motivated to feed recycled char into the bottom bed. Also fresh fuel is added to this flow of material entering in the bottom.
- A fluidized duct below the reactors returns the circulated materials from the fuel reactor to the air reactors.
- The fuel reactor has similar height as the FBC boiler in order to maximize char conversion.
- The air reactors are shortened because air reactor height has no benefits as there are no homogeneous gas phase reactions that should be brought to completion. Furthermore a lower air reactor riser has the advantage of giving increased solids circulation.

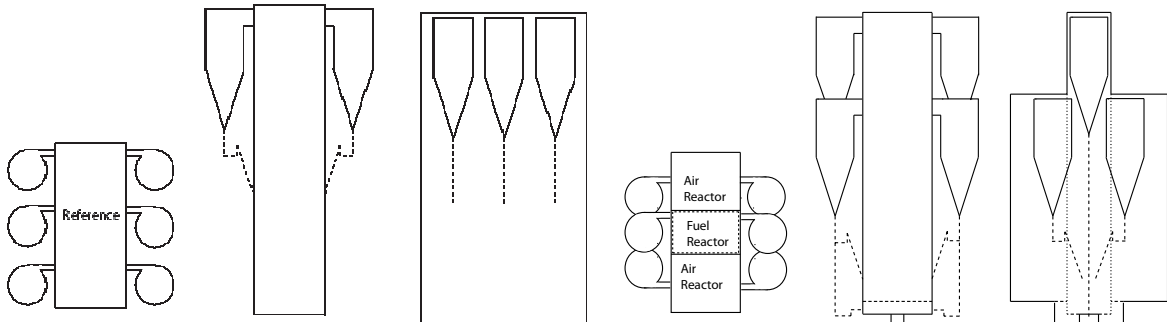

Figure 10. Left: layout of 1000 MWth FBC boiler, Right: Layout of 1000 MWth CLC boiler. From [63].

- The adiabatic fuel reactor will give added costs for insulated walls that are not used for steam generation. On the other hand, the heat transfer in the air reactor is almost doubled because of higher temperature in the air reactor, leading to a significant reduction in heat transfer area.
- Not shown in the figure is the post-oxidation chambers where final oxidation of the gas from the fuel reactor takes place. Oxygen can be added in the cyclone outlets and the ducts leading from the cyclones may serve the purpose of post-oxidation chambers.
- The fuel reactor will have a high bottom bed height in order to achieve both good gas conversion and long residence time of the char particles to be gasified. Lower bed height is needed in the air reactor, but the bed levels

will be approximately similar because of the connecting duct. Therefore, the floor of the air reactor is raised as compared to the fuel reactor to avoid unnecessary pressure drop in the air reactor.

### 3.2. Extrapolation of small scale pilot results

The work reported of more than 9000 h of operation and >3000 h with low-cost materials is a clear indication that CLC is technically feasible. However, it is important to recognize that the results obtained in small scale pilots, cannot give any safe answers to questions related to performance in large scale. This is because of the inherent differences in small and large fluidized beds:

- A high bed height in a small pilot, inevitably gives a large height/width ratio. This results in slugging conditions. Thus, conditions will be quite different from the large cross-section of the full scale.
- A small scale pilot with a riser height of perhaps 5 m, cannot use the high velocities typical of a ten times higher full-scale unit.
- Because of different velocities and the much higher height, a large-scale riser may hold a much higher amount of solid material. Because of good gas-solids contact in the riser, this can be expected to contribute to lower the oxygen demand.
- Because of different velocities, the dense bottom bed can be expected to show much more gas-bypass and less efficient gas-solids contact in the large scale.
- The much higher riser of the full-scale unit will provide additional residence time for the fine char elutriated, thus improving conversion. Secondly, it can be assumed that a full-scale cyclone is much more efficient in capturing and returning the fine char to the fuel reactor. The combined effect of a ten times higher riser and more efficient recycling of fine char, is likely to reduce loss of char very significantly.

Although pilot operation is important to gain further insights into *e.g.* the performance of various oxygen carriers, further work will not answer key questions related to performance in full-scale like the effect of high riser and higher velocity. There is only one way of finding this out, which is the demonstration of the technology in large units. It can be discussed whether we know enough about the technology to go for the full-scale already now. But, as said, further pilot operation will not bring us significantly closer to the knowing the outcome of a large-scale operation. Consequently, there is no good reason to wait with scaling-up. Therefore it is reasonable to conclude that the technology is ready for scale-up.

Risks, and risk management, in up-scaling have previously been discussed. [63]

### 3.3. Key challenges

Clearly, the experiences and know-how from CFB technology are central for CLC. However, there are also a number of important differences that have to be properly addressed to make the CLC technology work:

- 1) It is absolutely necessary to have an excellent control of circulation. Loss in circulation stops will stop conversion and heat generation within a minute or so. Also, the circulation must be right, if too low there will be a loss in fuel reactor temperature, and if too high, there will be a loss in CO<sub>2</sub> capture. A number of different systems have been tried, and works well, in small pilot scale. Needed circulation and circulation control in CLC have previously been discussed, [63]. Options for control include particle size, fluidizing velocity, secondary air fraction, split loop-seal and additional separate riser.
- 2) Suitable oxygen carrier materials. The literature cited above shows that a number of low cost materials have been shown to work well in pilot operation.
- 3) Loss of char to air reactor and by elutriation. Adequate fuel size, sufficient solids inventory and sufficient temperature are needed.

4) Gas conversion in fuel reactor. As discussed above, scale-up of the fuel reactor, assuming an internally circulating fluidized bed, will mean a much higher riser. Increased height involves increased pressure drop in the riser, i.e. the gas will be in contact with more oxygen carrier, which should improve conversion. On the other hand, less efficient gas-solids contact could be expected in the bottom bed. Given the restrictions of oxygen carrier cost and imperfect gas-solids contact in the fuel reactor, a certain oxygen demand can be expected. The best solution is likely an oxy-polishing step immediately after the fuel cyclone outlet.

5) Downstream treatment. After the fuel reactor an oxygen polishing step is foreseen, where the gas is fully oxidized to H<sub>2</sub>O and CO<sub>2</sub>, and also reduced sulphur and nitrogen compounds are oxidized. This step will produce a gas similar to that of oxy-combustion, albeit with considerably less argon. Thus, the gas from the oxy-polishing step can be treated in a similar way as planned for oxy-fuel process. This involves downstream steps for making the CO<sub>2</sub> stream pure enough for storage, which would involve condensation and removal of moisture, removal of acid gases and oxygen, and CO<sub>2</sub> compression.

### 3.4. Recommendations

Based on the work on chemical-looping reported in the literature, especially the operational experiences, it is recommended that the following points are considered for scale-up:

- When possible, use existing and proven CFB technology.
- Assure that circulation and control of circulation is adequate.
- Use intermediate sized fuel to avoid carbon loss and low CO<sub>2</sub> capture
- Use high temperature in fuel reactor to reduce losses of char, preferably 980°C or higher
- Feed fuel in bottom of bed to assure contact between volatiles and bed material.
- Use high riser and efficient cyclone to minimize loss of char fines.
- Use high riser and high velocity to achieve high solids inventory in riser to give low oxygen demand.
- Use high solids inventory in fuel reactor and carbon stripper, to achieve sufficient residence time for char conversion, i.e. to reach high CO<sub>2</sub> capture.
- Investigate the possibility and usefulness of a high bottom bed, it is not clear if bubble growth makes the mass transfer in the upper part of such a bed very inefficient.
- Investigate the option to use internals in the bottom bed to reduce bubble size and improve gas-solids contact.
- Investigate the option to use a volatiles' distributor, [64]

## 4. Up-scaling and ways of reducing development cost

### 4.1. Cost structure

An analysis of the added costs of the CLC boiler as compared to the CFB boiler, shows that the major added costs are not associated with the boiler, Table 4. The largest cost is CO<sub>2</sub> compression, which is inevitable and common to all CO<sub>2</sub> capture technologies. The second largest cost is air separation for production of oxygen, assuming a gas conversion of 85-95% means that the need for oxygen is in the range 5-15% of that of oxyfuel CO<sub>2</sub> capture. Other added costs are related to oxygen carrier, insulation of fuel reactor, steam fluidization of fuel reactor and coal grinding. The total cost of CO<sub>2</sub> capture is estimated to be 20 €/tonne CO<sub>2</sub> and within the range of 16-26 €/tonne, depending on for instance the gas conversion attained in the fuel reactor and the life of the oxygen-carrier material.

The cost analysis is based on tangible differences between CLC and CFB technologies, which makes the analysis transparent. Thus, the analysis can easily be updated, should new and better information become available.

Table 4. Cost estimate of added costs for chemical-looping combustion. From [63].

Type of cost	Cost estimate €/tonne CO <sub>2</sub>	Cost range €/tonne CO <sub>2</sub>	Efficiency penalty, %
CO <sub>2</sub> compression	10	10	3
Oxy-polishing	6.5	4-9	0.5
Boiler cost	1	0.2-2.2	-
Oxygen carrier	2	1.3-4	-
Fuel reactor fluidization	0.8	0.8	0.8
Coal grinding	0.2	0.2	0.1
Lower air ratio	-0.5	-0.5	-0.5
Total	20	16-25.7	3.9

#### 4.2. Up-scaling at reduced costs

The scaling-up of CLC to commercial size will need intermediate steps, which should verify the performance of the CLC process under conditions relevant for larger scale. In these steps CO<sub>2</sub> capture would normally have little relevance. This is an advantage and a simplification, avoiding process steps which are not necessary without CO<sub>2</sub> capture, like CO<sub>2</sub> purification and compression and oxygen production. The latter is not needed if the fuel reactor gas is oxidized with air. In Table 4, it is seen that the CO<sub>2</sub> capture and oxy-polishing is estimated to constitute more than 80% of the costs.

However, these costs are added costs compared to a CFB and even without these process steps, the costs of building a dedicated CLC demo of intermediate size would be significant. However, there could be options to further reduce demonstration costs, i.e. avoiding/reducing the costs of the “CFB”, that is the air reactor and the auxiliary systems:

- Adaptation of an existing CFB. Here the idea is to find an existing CFB unit of suitable size and design which is not in use or can be taken out of operation for a period. This would then be equipped with a fuel reactor.
- A possible variant of adaptation of an existing CFB is to extract a part of the circulating flow to a fuel reactor that only converts a part of the total fuel, e.g. adding for instance a 10 MW fuel reactor to a 100 MW boiler. Because many CFBs operate at lower temperature than that expected in CLC an option is to use burners to increase the temperature of the material going to the fuel reactor. The gas from the fuel reactor can be led into the CFB riser, thus avoiding any need for treatment. As the whole system needs to operate with oxygen-carrier material, a biomass-fired CFB would be convenient as no limestone for SO<sub>2</sub> capture is needed.
- Dual purpose CLC/CFB. Here the idea is to build a CLC reactor system to demonstrate the CLC technology, but where the air reactor with some modifications can be used as a CFB boiler after the demonstration period.

The strategy in these approaches is to avoid, or minimize, the costs of air reactor and the peripheral systems. The fuel reactor is necessary in CLC, and likely of no use except in CLC, which means that the cost of the fuel reactor is not easily avoided. The fuel reactor itself is expected to have moderate added costs because the walls are adiabatic. For example cost of the fuel reactor walls of a 1000 MW<sub>th</sub> unit including cyclones, channels etc., was estimated to 4 M€ [63]. This is in fact only a few per cent of the estimated power plant cost.

## 5. Conclusions

The necessary elements for a scale-up are at hand:

- Different oxygen carrier materials of low cost have been tested in extended operation and found to have reasonable performance with respect to reactivity and life time.
- Operation with solid fuels in pilots up to at least 100 kW has been shown to work. Operation in a 1 MW pilot showed inadequate loss of char but reasons for this are understood and can be addressed.
- Designs for large-scale units have been done indicating that the process is technically realistic and should have low cost of CO<sub>2</sub> capture.

- A scale-up strategy to minimize costs has been suggested.

## 6. Acknowledgement

The research leading to these results received funding from the European Research Council under the Seventh Framework Programme ERC Grant Agreement n° 291235 of the European Union.

## 7. References

- [1] J. Adánez, A. Abad, F. Garcia-Labiano, et al. Progress in Chemical-Looping Combustion and Reforming technologies. *Progress in Energy and Combustion Science* 2012; **38**:215–282.
- [2] L.-S. Fan, (2010) *Chemical Looping Systems for Fossil Energy Conversions*: John Wiley & Sons.
- [3] A. Lyngfelt. Chemical looping combustion. In: F. Scala, editor. *Fluidized-bed technologies for near-zero emission combustion and gasification*, Woodhead Publishing Limited; 2013, p. 895-930.
- [4] A. Lyngfelt. Chemical-looping combustion of solid fuels – status of development. *Applied Energy* 2014; **113**:1869-1873.
- [5] A. Lyngfelt. Oxygen carriers for chemical-looping combustion - 4000 h of operational experience. *Oil & Gas Science and Technology - Revue d'IFP Energies nouvelles* 2011; **66**:161-172.
- [6] T. Mattisson, A. Lyngfelt, and H. Leion. Chemical-looping oxygen uncoupling for combustion of solid fuels *International Journal of Greenhouse Gas Control* 2009; **3**:11-19.
- [7] T. Mattisson, H. Leion, and A. Lyngfelt. Chemical-looping with oxygen uncoupling using CuO/ZrO<sub>2</sub> with petroleum coke. *Fuel* 2009; **88**:683-690.
- [8] H. Leion, T. Mattisson, and A. Lyngfelt. Combustion of a German lignite using chemical-looping with oxygen uncoupling (CLOU). In: *The Clearwater Coal Conference - The 33rd International Technical Conference on Coal Utilization & Fuel Systems*. Clearwater, Florida; 2008
- [9] A. Abad, I. Adánez-Rubio, P. Gayán, et al. Demonstration of chemical-looping with oxygen uncoupling (CLOU) process in a 1.5kW<sub>th</sub> continuously operating unit using a Cu-based oxygen-carrier. *International Journal of Greenhouse Gas Control* 2012; **6**:189-200.
- [10] M. Rydén, H. Leion, T. Mattisson, et al. Combined oxides as oxygen carrier material for chemical-looping with oxygen uncoupling. *Applied Energy* 2014; **113**:1924-1932.
- [11] G. Azimi, M. Rydén, H. Leion, et al. (Mn<sub>y</sub>Fe<sub>1-y</sub>)O<sub>x</sub> combined oxides as oxygen carrier for chemical-looping combustion with oxygen uncoupling (CLOU). *AIChE J.* 2013; **59** 582-588.
- [12] M. Källén, M. Rydén, C. Dueso, et al. CaMn<sub>0.9</sub>Mg<sub>0.103-δ</sub> as Oxygen Carrier in a Gas-Fired 10 kW<sub>th</sub> Chemical-Looping Combustion Unit. *Industrial & Engineering Chemistry Research* 2013; **52** 6923-6932.
- [13] M. Rydén, A. Lyngfelt, Ø. Langørgen, et al. Negative CO<sub>2</sub> Emissions with Chemical-Looping Combustion of Biomass – a Nordic Energy Research Flagship Project. In: *13<sup>th</sup> International Conference on Greenhouse Gas Control Technologies, GHGT-13*. Lausanne, Switzerland; 2016
- [14] A. Lyngfelt and T. Mattisson. Chapter 11. Oxygen Carriers for Chemical-Looping Combustion. In: P. Fennell and E.J. Anthony, editors. *Calcium and Chemical Looping Technology for Power Generation and Carbon Dioxide (CO<sub>2</sub>) Capture*, Woodhead Publishing; 2014.
- [15] M. Rydén, P. Moldenhauer, S. Lindqvist, et al. Measuring attrition resistance of oxygen carrier particles for chemical looping combustion with a customized jet cup. *Powder Technology* 2014; **256**:75-86.
- [16] A. Lyngfelt, B. Kronberger, J. Adánez, et al. *The GRACE project. Development of oxygen carrier particles for chemical-looping combustion. Design and operation of a 10 kW chemical-looping combustor*. in *7th International Conference on Greenhouse Gas Control Technologies*. Vancouver.(2004)
- [17] A. Lyngfelt and H. Thunman. Construction and 100 h of operational experience of a 10-kW chemical-looping combustor. *Carbon Dioxide Capture for Storage in Deep Geologic Formations--Results from the CO<sub>2</sub> Capture Project* 2005; **1**:625-645.
- [18] H.-J. Ryu, G.-T. Jin, and C.-K. Yi. *Demonstration of inherent CO<sub>2</sub> separation and no NO<sub>x</sub> emission in a 50 kW chemical-looping combustor: continuous reduction and oxidation experiment*. in *Proceedings of the 7th International Conference on Greenhouse Gas Control Technologies*. Vancouver.(2004)
- [19] J. Adanez, P. Gayan, J. Celaya, et al. Chemical Looping Combustion in a 10 kW<sub>th</sub> Prototype Using a CuO/Al<sub>2</sub>O<sub>3</sub> Oxygen Carrier: Effect of Operating Conditions on Methane Combustion. *Industrial & Engineering Chemistry Research* 2006; **45**:6075-6080.
- [20] E. Johansson, T. Mattisson, A. Lyngfelt, et al. Combustion of syngas and natural gas in a 300 W chemical-looping combustor. *Chemical Engineering Research and Design* 2006; **84**:819-827.
- [21] A. Lyngfelt. Chemical-looping combustion of solid fuels. *Greenhouse Gas Issues* 2007:9-10.
- [22] N. Berguerand and A. Lyngfelt. Design and operation of a 10 kW<sub>th</sub> chemical-looping combustor for solid fuels - Testing with South African coal. *Fuel* 2008; **87**:2713-2726.
- [23] J. Adánez, C. Dueso, L. F. D. Diego, et al. Methane combustion in a 500 W<sub>th</sub> chemical-looping combustion system using an impregnated ni-based oxygen carrier. *Energy and Fuels* 2009; **23**:130-142.
- [24] S. R. Son and S. D. Kim. Chemical-Looping Combustion with NiO and Fe<sub>2</sub>O<sub>3</sub> in a Thermobalance and Circulating Fluidized Bed Reactor with Double Loops. *Industrial & Engineering Chemistry Research* 2006; **45**:2689-2696.
- [25] P. Kolbitsch, J. Bolhàr-Nordenkamp, T. Pröll, et al. Comparison of two Ni-based oxygen carriers for chemical looping combustion of natural gas in 140 kw continuous looping operation. *Industrial and Engineering Chemistry Research* 2009; **48**:5542-5547.
- [26] T. Mattisson, J. Adánez, T. Proell, et al. Chemical-looping Combustion CO<sub>2</sub> Ready Gas Power. *Energy Procedia* 2009; **1**:1557-1564.

- [27] L. Shen, J. Wu, J. Xiao, et al. Chemical-looping combustion of biomass in a 10 kW reactor with iron oxide as an oxygen carrier. *Energy and Fuels* 2009; **23**:2498-2505.
- [28] H.-J. Ryu, S.-H. Jo, Y. C. Park, et al. Long-term operation experience in a 50 kW<sup>th</sup> chemical looping combustor using natural gas and syngas as fuels. In: *1st International Conference on Chemical Looping*. Lyon; 2010
- [29] J. Wu, L. Shen, J. Hao, et al. Chemical looping combustion of coal in a 1 kW<sup>th</sup> reactor. In: *1st International Conference on Chemical Looping*. Lyon; 2010
- [30] H. Gu, L. Shen, J. Xiao, et al. Chemical looping combustion of biomass/coal with natural iron ore as oxygen carrier in a continuous reactor. *Energy and Fuels* 2011; **25**:446-455.
- [31] S. Riffart, A. Hoteit, M. Yazdanpanah, et al. Construction and operation of a 10kW CLC unit with circulation configuration enabling independent solid flow control. *Energy Procedia (GHGT-10) in press* 2010.
- [32] Sozinho T, Pelletant W, Gauthier T, et al. Main results of the 10 kW coal pilot plant operation. . In: *2nd Int. Conf. on Chemical Looping*. Darmstadt; 2012
- [33] A. R. Bidwe, F. Mayer, C. Hawthorne, et al. Use of ilmenite as an oxygen carrier in chemical looping combustion-batch and continuous dual fluidized bed investigation. *Energy Procedia* 2011; **4**:433-440.
- [34] S. Wang, G. Wang, F. Jiang, et al. Chemical looping combustion of coke oven gas by using Fe<sub>2</sub>O<sub>3</sub>/CuO with MgAl<sub>2</sub>O<sub>4</sub> as oxygen carrier. *Energy and Environmental Science* 2010; **3**:1353-1360.
- [35] A. Cuadrat, A. Abad, F. Garcia-Labiano, et al. The use of ilmenite as oxygen-carrier in a 500W<sup>th</sup> Chemical-Looping Coal Combustion unit. *International Journal of Greenhouse Gas Control* 2011; **5**:1630-1642
- [36] P. Moldenhauer, M. Rydén, T. Mattisson, et al. Chemical-Looping Combustion and Chemical-Looping Combustion with Oxygen Uncoupling of Kerosene with Mn- and Cu-based Oxygen Carriers in a Circulating Fluidized-Bed 300W Laboratory Reactor. *Fuel Processing Technology* 2012; **104**:378–389.
- [37] P. Markström, C. Linderholm, and A. Lyngfelt. Operation of a 100 kW chemical-looping combustor with Mexican petroleum coke and Cerrejón coal. In: *2nd International Conference on Chemical Looping*. Darmstadt; 2012
- [38] P. Markström, C. Linderholm, and A. Lyngfelt. Chemical-looping combustion of solid fuels - Design and operation of a 100 kW unit with bituminous coal. *International Journal of Greenhouse Gas Control* 2013; **15**:150-162.
- [39] Thon A, Kramp M, Hartge EU, et al. Operational experience with a system of coupled fluidized beds for chemical looping combustion of solid fuels using ilmenite as oxygen carrier *Applied Energy* 2014; **Volume 118**:309–317.
- [40] H. Kim, D. Wang, L. Zeng, et al. Coal direct chemical looping combustion process: Design and operation of a 25-kW<sup>th</sup> sub-pilot unit *Fuel* 2013; **108**:370-384.
- [41] S. Bayham, H. Kim, D. Wang, et al. Iron-based coal direct chemical looping combustion process: 200-h continuous operation of a 25-kW<sup>th</sup> subpilot unit *Energy and Fuels* 2013; **27**:1347-1356.
- [42] R. Xiao, L. Chen, C. Saha, et al. Pressurized chemical-looping combustion of coal using an iron ore as oxygen carrier in a pilot-scale unit. *International Journal of Greenhouse Gas Control* 2012; **10**:363–373.
- [43] J. Bao, Z. Li, H. Sun, et al. Continuous Test of Ilmenite-Based Oxygen Carriers for Chemical Looping Combustion in a Dual Fluidized Bed Reactor System. *Ind. Eng. Chem. Res.* 2013; **52**:14817–14827.
- [44] J. Ströhle, M. Orth, and B. Epple. Chemical Looping Combustion of Hard Coal in a 1 MW<sub>th</sub> Pilot Plant Using Ilmenite as Oxygen Carrier. *Applied Energy* 2015; **157**:288–294.
- [45] P. Ohlemüller, J.-P. Busch, M. Reitz, et al. Chemical-Looping Combustion of Hard Coal: Autothermal Operation of a 1 MW<sup>th</sup> Pilot Plant. *J. Energy Resour. Technol.* 2016; **138**:042203-1-042203-7.
- [46] I. Abdullally, C. Beal, H. Andrus, et al. Alstom's Chemical Looping Technology, Program Update. In: *11th Annual Conference on Carbon Capture Utilization & Sequestration* Pittsburgh, Pennsylvania; 2014
- [47] A. Abad, R. Pérez-Vega, L. De Diego, et al. Design and operation of a 50 kW<sup>th</sup> Chemical Looping Combustion (CLC) unit for solid fuels. *Applied Energy* 2015; **157**:295–303.
- [48] J. Ma, H. Zhao, X. Tian, et al. Chemical looping combustion of coal in a 5 kW<sup>th</sup> interconnected fluidized bed reactor using hematite as oxygen carrier. *Applied Energy* 2015; **157**:304–313.
- [49] S. Huseyin, G. Wei, H. Li, et al. Chemical-looping gasification of biomass in a 10 kW<sup>th</sup> interconnected fluidized bed reactor using Fe<sub>2</sub>O<sub>3</sub>/Al<sub>2</sub>O<sub>3</sub> oxygen carrier *Journal of Fuel Chemistry and Technology* 2014; **42**:922–931.
- [50] H. Ge, L. Shen, F. Feng, et al. Experiments on biomass gasification using chemical looping with nickel-based oxygen carrier in a 25 kW<sup>th</sup> reactor. *Applied Thermal Engineering* 2015; **85**:52–60.
- [51] J.-I. Baek, U. Kim, H. Jo, et al. Chemical Looping Combustion Development in Korea. In: *4<sup>th</sup> International Conference on Chemical Looping*. Nanjing, China; 2016
- [52] J. Ma, H. Zhao, Pengjie Niu, et al. Design and Operation of a 50 kW<sup>th</sup> Chemical Looping Combustion (CLC) Reactor Using Coal as Fuel. In: *4<sup>th</sup> International Conference on Chemical Looping*. Nanjing, China; 2016
- [53] Ø. Langørgen, I. Saanum, and N. E. L. Haugen. Performance of a 150 kW chemical looping combustion reactor system for gaseous fuels using a copper-based oxygen carrier. In: *4<sup>th</sup> International Conference on Chemical Looping*. Nanjing, China; 2016
- [54] T. Pikkarainen, I. Hiltunen, and S. Teir. Piloting of bio-CLC for BECCS. In: *4<sup>th</sup> International Conference on Chemical Looping*. Nanjing, China; 2016
- [55] R. Siriwardane, H. Tian, J. Riley, et al. Commercial Scale Preparations of CuO-Fe<sub>2</sub>O<sub>3</sub>-Alumina Oxygen Carrier with various techniques: Bench Scale Fluidized Bed Tests with Coal/Air and Methane/air and Pilot Scale (51 Kw<sup>th</sup>) Chemical Looping Combustion Tests with Methane/Air. In: *4<sup>th</sup> International Conference on Chemical-Looping*. Nanjing, China; 2016
- [56] T. B. Vilches, F. Lind, M. Rydén, et al. Experience of more than 1000h of operation with oxygen carriers and solid biomass at large scale. In: *4<sup>th</sup> International Conference on Chemical Looping*. Nanjing, China; 2016
- [57] B.-Å. Andersson, F. Lind, A. Corcoran, et al. 4000 Hours of Operation with Oxygen-Carriers in Industrial Relevant Scale (75 MW<sub>th</sub>). In: *4<sup>th</sup> International Conference on Chemical Looping*. Nanjing, China; 2016

- [58] A. Lyngfelt and P. Markström, *Film showing cold-flow model of the 100 kW unit in operation*. 2012: <http://www.entek.chalmers.se/lyngfelt/co2/CFM.htm>.
- [59] C. Linderholm, P. Knutsson, M. Schmitz, et al. Material balances of carbon, sulfur, nitrogen and ilmenite in a 100 kW CLC reactor system. *International Journal of Greenhouse Gas Control* 2014; **27**:188-202.
- [60] C. Linderholm, M. Schmitz, P. Knutsson, et al. Chemical-Looping Combustion in a 100-kW Unit using a Mixture of Ilmenite and Manganese Ore as Oxygen Carrier. *Fuel* 2016; **166**:533–542.
- [61] C. Linderholm, M. Schmitz, M. Biermann, et al. Chemical-looping combustion of solid fuel in a 100 kW unit using sintered manganese ore as oxygen carrier. *To be submitted* 2016.
- [62] R. Pérez-Vega, A. Abad, F. García-Labiano, et al. Coal combustion in a 50 kWth Chemical Looping Combustion unit: Seeking operating conditions to maximize CO<sub>2</sub> capture and combustion efficiency. *International Journal of Greenhouse Gas Control* 2016; **50**:80–92.
- [63] A. Lyngfelt and B. Leckner. A 1000 MW<sub>th</sub> Boiler for Chemical-Looping Combustion of Solid Fuels – Discussion of Design and Costs. *Applied Energy* 2015; **157**:475-487.
- [64] A. Lyngfelt. Solid fuels in Chemical-Looping Combustion – Feeding of fuel and distribution of volatiles In: *22<sup>nd</sup> International Conference on Fluidized Bed Conversion*. Turku, Finland; 2015